

Din Sync

# RE-909

## Additional Advisory

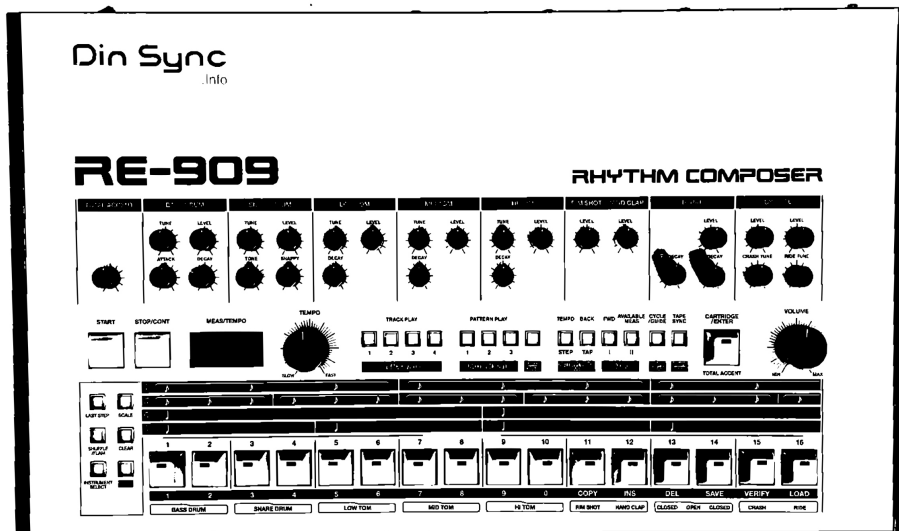

# RE-909 Additional Advisories:

v0.1F

Acknowledgements:

Thank you to Jesús Gallego, and Colten Noakes, and David Sotnick for their help with this document.

This was produced as the result of a group formed on instagram to better assist that group with building, debugging, and making fine adjustments to our RE-909 builds. It's not an official document, rather, it is a collection of tips which were very helpful to us along the way.

While we hope this is helpful, it is also our wish that you form your own groups, and begin your own conversations in order to refine, and perfect your projects in the way that you feel is best.

Glad to be sharing with the greater community in this way. Good luck to you!

## CONTENTS

1. Ground Issue/Crosstalk Fix
2. SD Gain Scaling
3. Switchboard PCB Error
- 3A. Cabling Guide
4. MIDI IN PCB Error
5. SD Envelope Fix
6. Battery Terminals
7. Matching Transistors
8. Switchboard Electrolytic Capacitor Guidance

## 1- OVERALL GROUND ISSUE FIX - GROUND & CROSSTALK FIX

Hi, just wanted to share some good news about noise and crosstalk issues on RE-909. Pictured below is a Roland TR-909 factory mod with a wire that seems to reinforce grounding between C151 styrofoam cap in the hihat low pass filter and the common analog ground track where R236 is also attached. By doing the same mod in RE-909, pictured below also in the bottom of the board, cymbals crosstalk and digital noise leak into the hihats channel is eliminated, which fixes the last remaining issue in my build. I used a thick grounding wire to connect the lower pin of C151 to the double hole in the common ground track next to R236. This fix works perfectly on trafo PSU but I can't guarantee it works on safe PSU (and preliminary tests show it doesn't) because of the difference in ground routing. Otherwise, enjoy your digital noise-free, crosstalk-free RE-909!

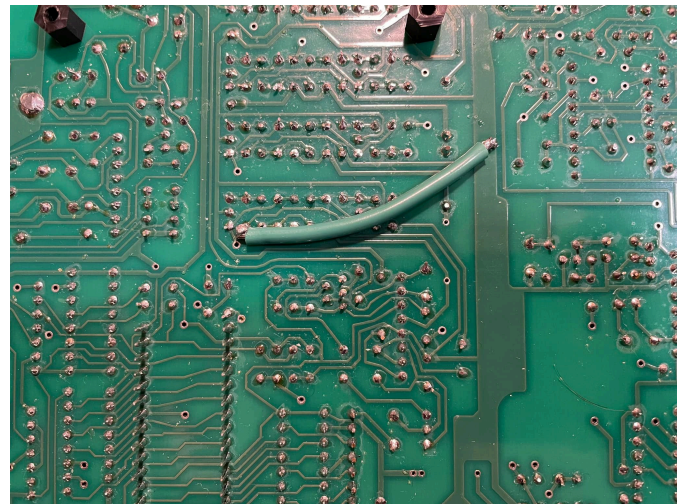
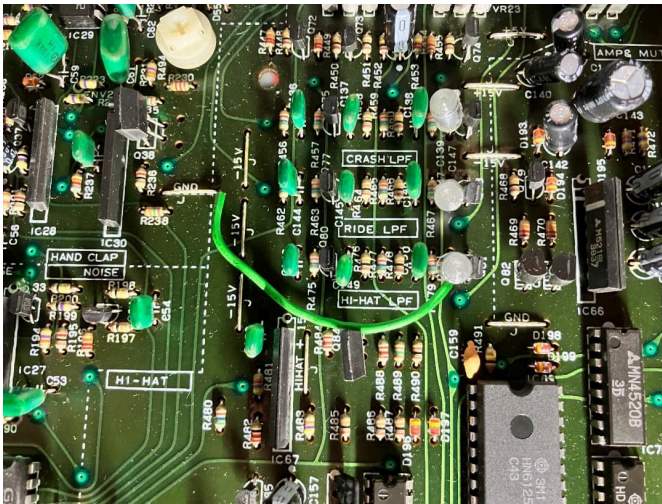

## 2 - SD GAIN SCALING

Heads up for those who commented about their snare snappy being way too loud compared to the original. Some of us worked together to look for a cause and we finally did find something. It took a bit to locate an original TR-909 to analyse under the scope but once that was available it was easy to see.

We followed the path of the noise signal in the snappy section of the snare in R286 right up to the Q47 and Q48 VCA transistors and noticed it was exactly the same as the TR up until the voltage divider resistors R298 and R279 where the signal was roughly doubled. We repeated this measurement across 3 RE-909 (first and second run) builds and one (second run) which didn't have this issue at all. We believe ground impedance could affect some builds, which in turn could interfere in the voltage divider resistors. We measured 4Vpp noise (3V avg) in the snappy noise measurement point (between C78 and R294) in RE-909 builds vs 1,70Vpp (1,2V avg) in a TR-909. Carter Goertzen used a potentiometer to match the noise gain exactly to the TR and a solution was found by replacing R294 with a 1% 200K. This value might be more or less universal if your snappy noise measurements match ours. We compared the output to other 3 TR-909 samples and the result behaves like those and finally feels much better balanced. Another possible fix would be to play with R298 and R279 values and 1% resistors to counter impedance before the VCAs and get the gain right but it doesn't seem as practical IMO.

### 3 - SWITCHBOARD PCB ERROR

The pin numbers of the switchboard connectors were incorrect on the initial run. See the pin out/destination diagram from the service notes (above) and be sure of your pins and destinations on your switch board (below). Check twice, solder once.

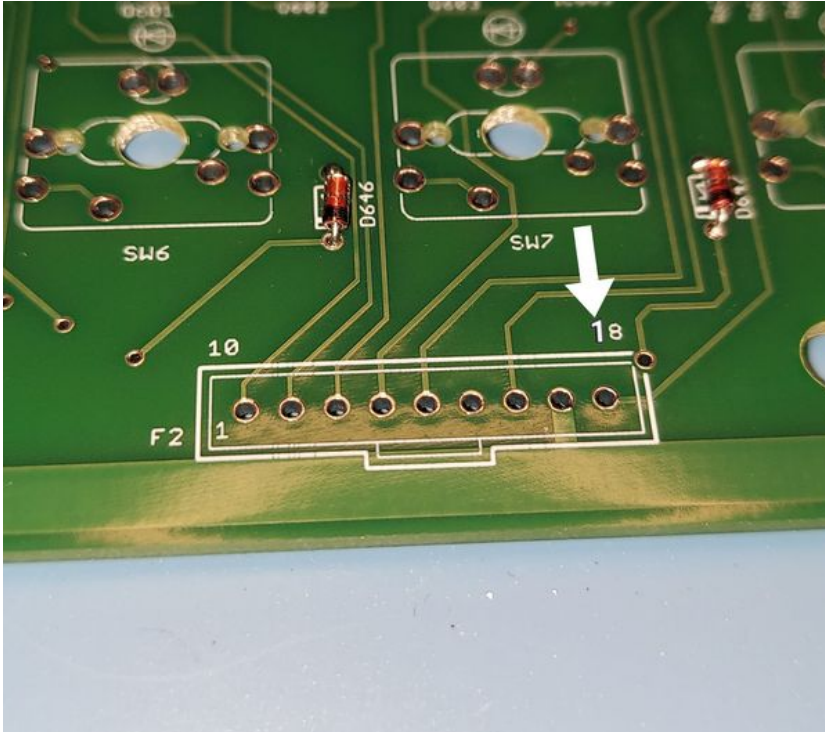
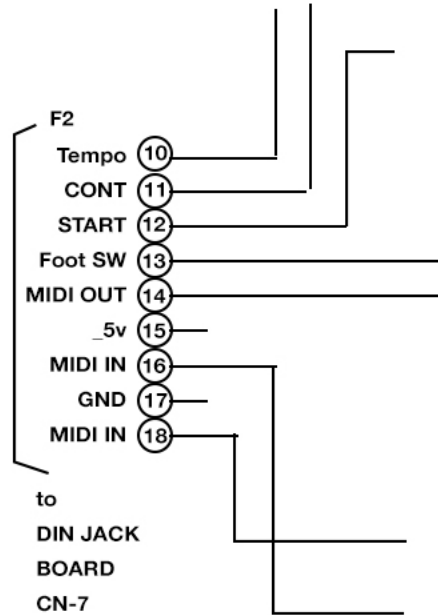
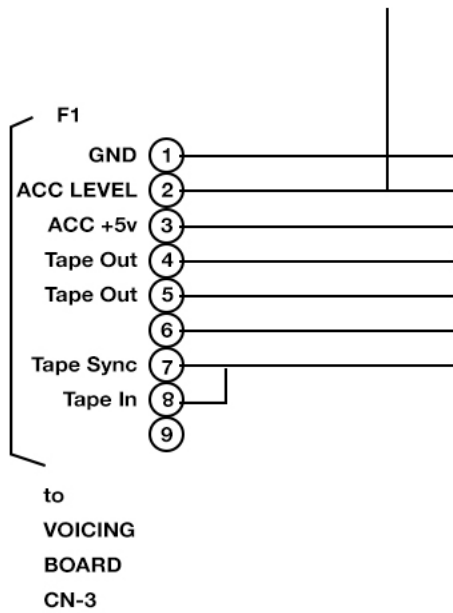

## 3A - RE-909 Cabling Guide

### Switch Board F1 to Voicing Board CN3

1 – 29  
2 – 28  
3 – 27  
4 – 26  
5 – 25  
6 – 24  
7 – 23  
8 – 22  
9 – 21

### Switch Board F2 to DIN Jack Board CN7

10 – 10  
11 – 11  
12 – 12  
13 – 13  
14 – 14  
15 – 15  
16 – 16  
17 – 17  
18 – 18

### Switch Board F3 to Voicing Board CN1

19 – 1  
20 – 2  
21 – 3  
22 – 4  
23 – 5  
24 – 6  
25 – 7  
26 – 8  
27 – 9  
28 – 10

|\_\_ **Disconnect for safety PSU**  
|

### Switch Board F4 to Voicing Board CN2

29 – 11  
30 – 12  
31 – 13  
32 – 14  
33 – 15  
34 – 16  
35 – 17  
36 – 18  
37 – 19  
38 – 20

### Voicing Board W4 to DIN Jack Board CN4

30 – 30  
31 – 31  
32 – 32

### Voicing Board W5 to Multi Jack Board CN5

33 – 33  
34 – 34  
35 – 35  
36 – 36  
37 – 37  
38 – 38  
39 – 39  
40 – 40  
41 – 41  
42 – 42

### Voicing Board W6 to Multi Jack Board CN6

43 – 43  
44 – 44  
45 – 45  
46 – 46  
47 – 47  
48 – 48

## 4 - MIDI IN PCB ERROR

We have noticed a small problem on the midi board, pin 2 from the midi in port is connected to ground and under certain circumstances this can lead to a buzz/hum when midi in is connected. Paul is going to update the build docs, here are photos of two possible ways how to fix it (not soldering pin 2 might be sufficient if it doesn't touch the pad):

1. Use a dremel or round file to remove the pad/increase the diameter of the hole to make sure pin 2 isn't connected to gnd or clip/remove pin 2 from the midi socket before soldering it
2. if you have already built the midi board and don't want to desolder the socket, cut a trace at 2 points and use a jumper to connect ground to pin 17 of the connector

### SUGGESTED:

**desolder the midi socket, lift (or cut) and isolate pin 2 and solder again.**

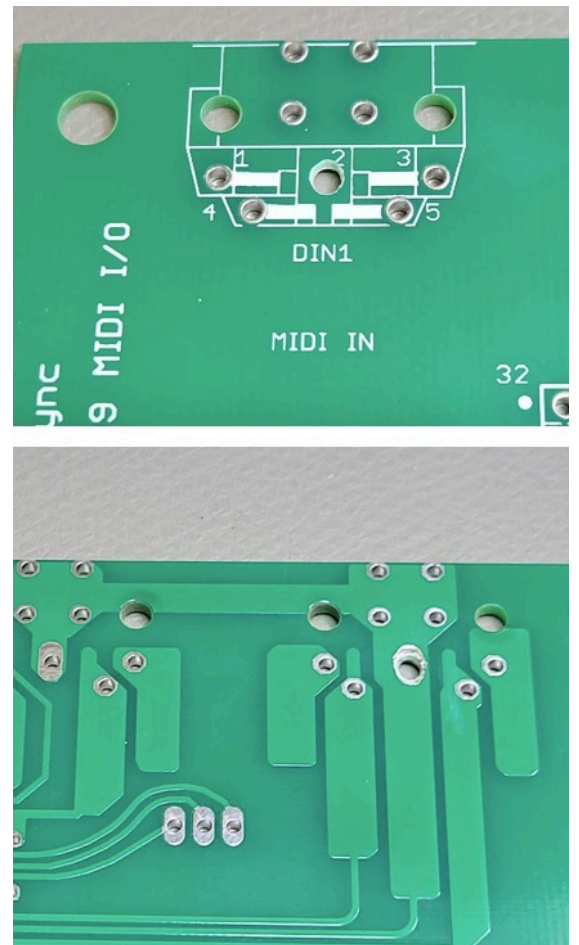

## 5 - SD ENVELOPE FIX

RE-909 service advisory 15-12-20

We found a minor error in the snare drum that didn't come up in testing. Its a simple fix with a single patch wire, please download v.1.7 build documentation for details.

Fixed in voice boards V2

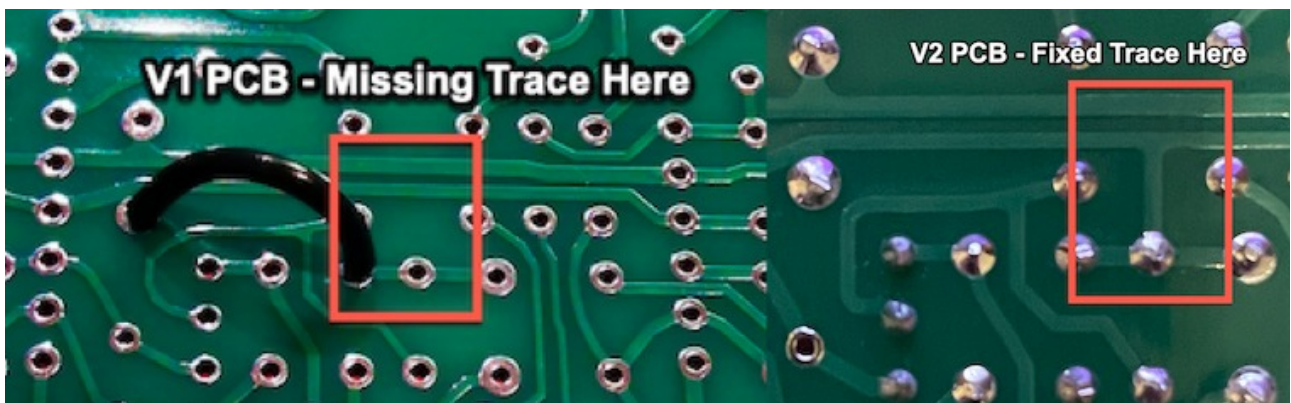

## 6 - BATTERY TERMINALS

Affects all pcb versions, fix improves/solves memory retention issues.

The battery terminal holes are missing the through hole plating, the fix is simple, please download V1.15 of the Build/Bom guide for more details.

## 7 - MATCHING TRANSISTORS

If you feel like there's volume inconsistencies across different instruments it's a good practice to select the transistors marked as S (selected) in the service manual to be roughly in the same HFE range

If you want to select the transistors you can measure them to be approximately in the same HFE range, for example between 300 and 350.

Q6 (BD)	Q28 (MT)	Q57 (HT)
Q12 (BD)		Q58 (HT)
	Q33 (Noise)	Q59 (HT)
Q19 (LT)		
Q20 (LT)	Q37 (CP)	Q65 (RS)
Q21 (LT)		
	Q50 (SD)	Q69 (HH/Cy)
Q26 (MT)	Q51 (SD)	Q71 (HH/Cy)
Q27 (MT)		Q85 (HH/Cy)

## 8 - SWITCHBOARD ELECTROLYTIC CAP GUIDANCE

Lay down all electrolytics under the switchboard (don't place them standing up)

There are clearance issues which present themselves intermittently later, because the metal cap of an electrolytic momentarily shorts a switchboard connection. this causes random crashes, stuck sequences, etcand it sucks. Lay those caps flat.

